



Renault C low cab 2014-

Art. 862353

Laternakandur WIDE | Lamp holder WIDE | Носител фар WIDE | Scheinwerferbügel WIDE

1. Kronstein / bracket / кронштейн / Konsole
2. Kronstein / bracket / кронштейн / Konsole
3. Kronstein / bracket / кронштейн / Konsole
4. Kronstein / bracket / кронштейн / Konsole
5. Kronstein / bracket / кронштейн / Konsole
6. Kronstein / bracket / кронштейн / Konsole
7. Kronstein / bracket / кронштейн / Konsole
8. Kronstein / bracket / кронштейн / Konsole
9. Laternaalus / lamp fixing bracket / крепежный кронштейн лампы / Lampenbefestigungsklammer
10. Mutter / nut / гайка / Mutter M8
11. Polt / bolt / болт / Bolzen M8x25 DIN7380-A2
12. Polt / bolt / болт / Bolzen M8x25 DIN933-A2
13. Seib / flat washer / шайба / Scheibe 8,4x24x2
14. Vedrusseib / spring washer / пружинная шайба / Federnscheibe A8

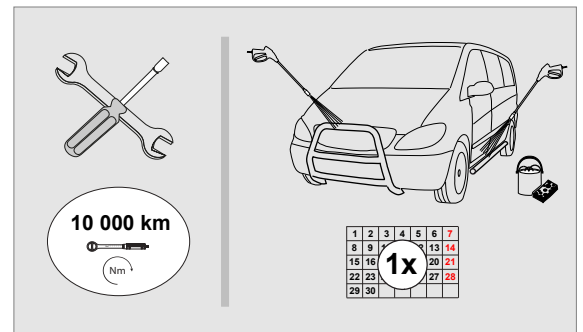
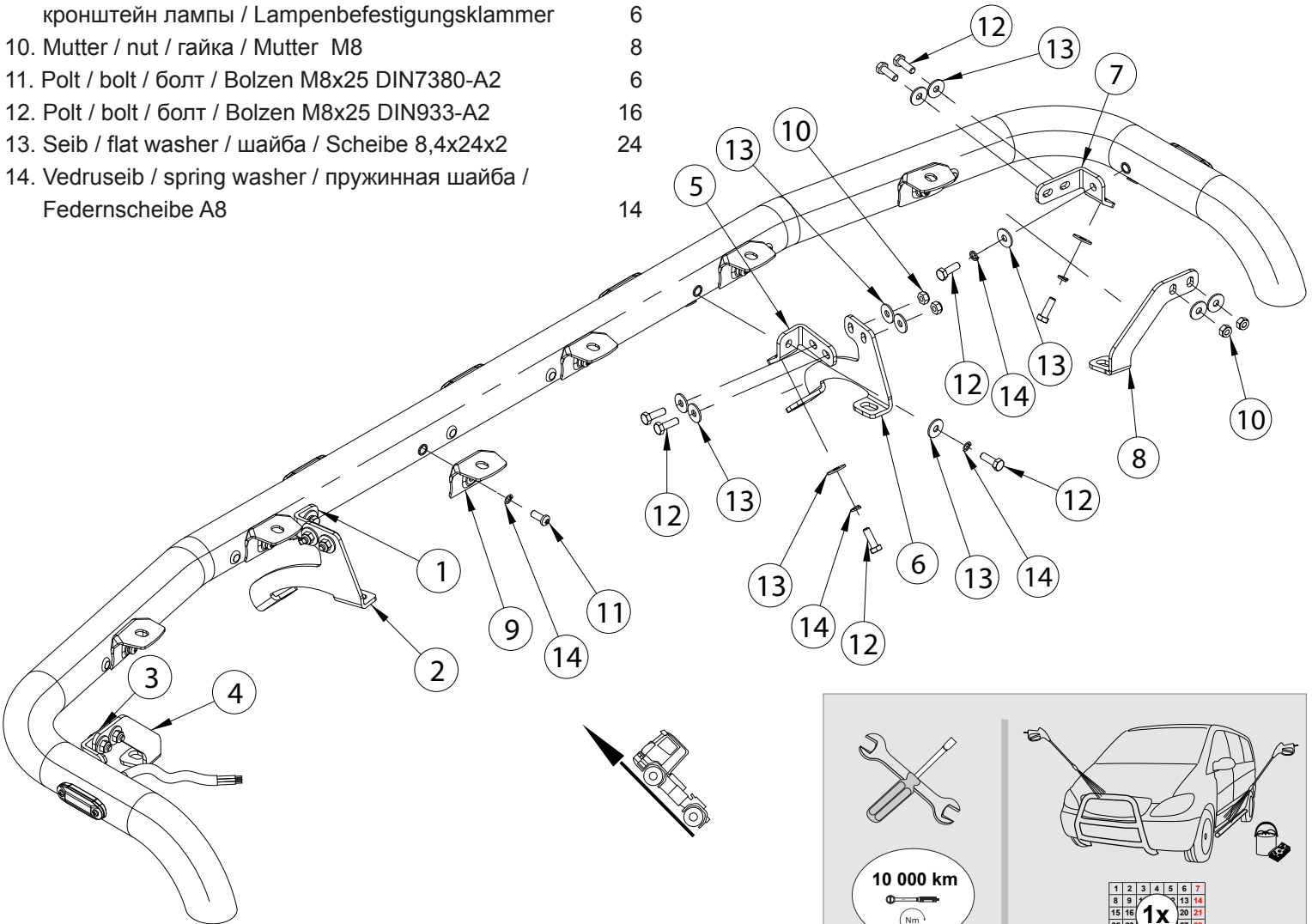

Kaal / Weight / Масса / Gewicht: 11,8 kg

Paigaldusaeg ilma elektritöödetä / Time of mounting w/o wiring works / Время установки без электромонт. работ / Einbauzeit ohne elektrische arbeit: 45 min

Vajalikud tööriistad / Required Tools / Необходимые инструменты / Benötigte Werkzeuge



M8 - 25 Nm

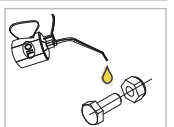

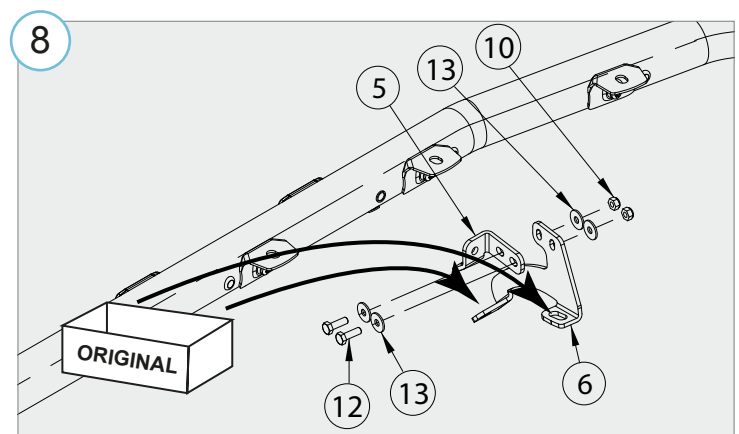
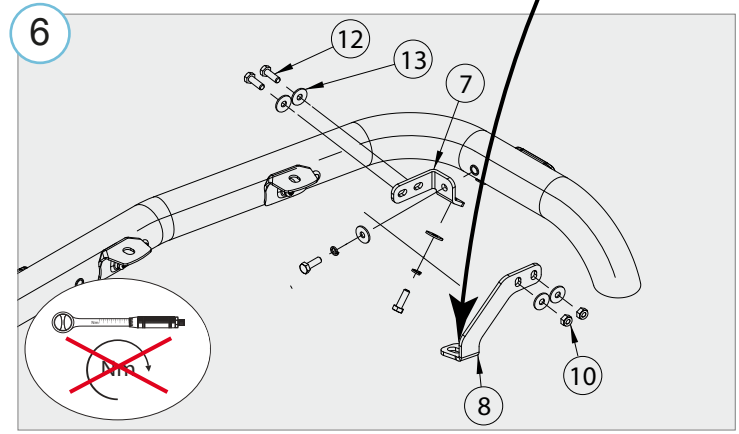
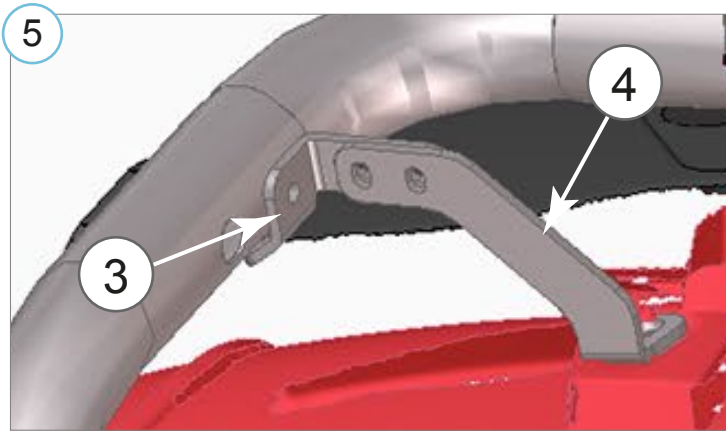
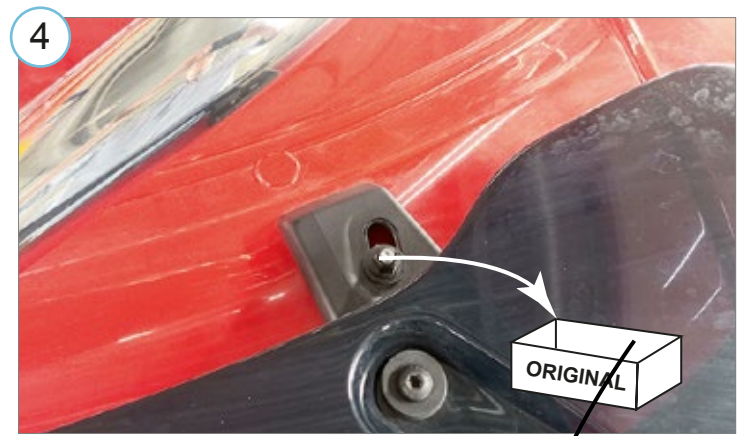
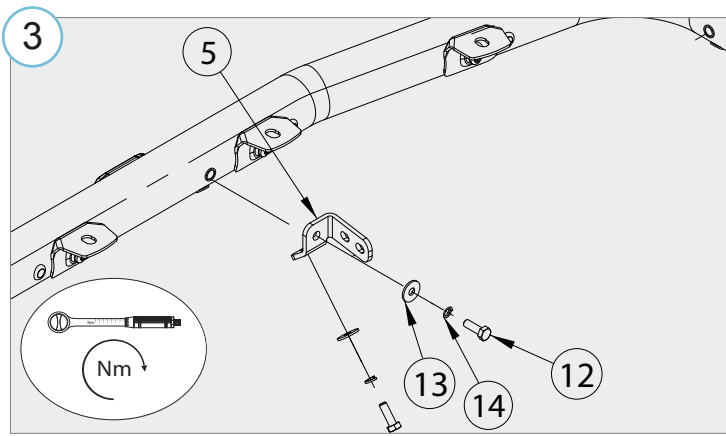
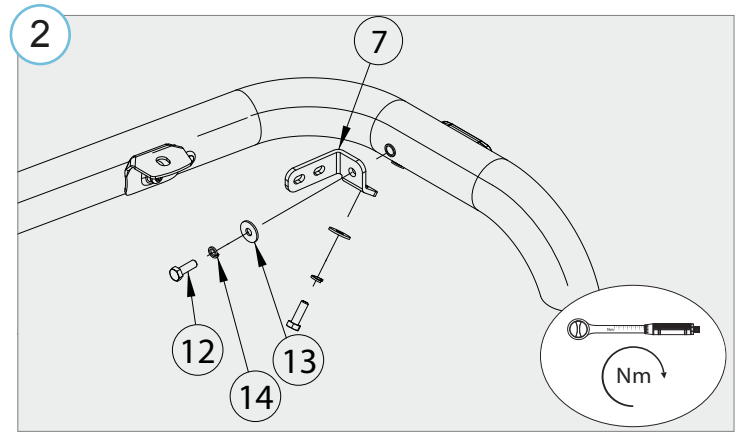
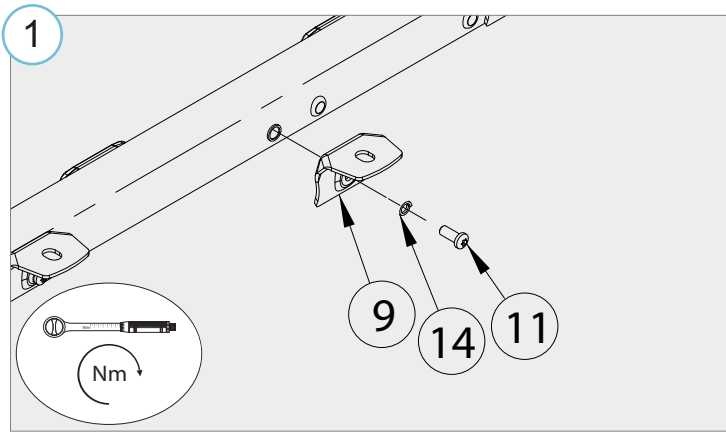

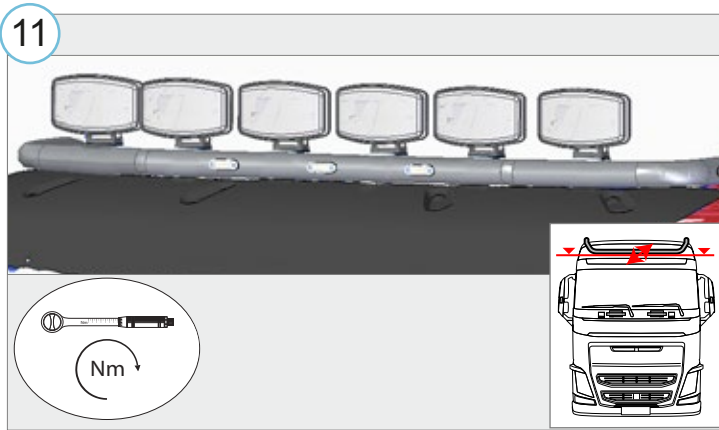
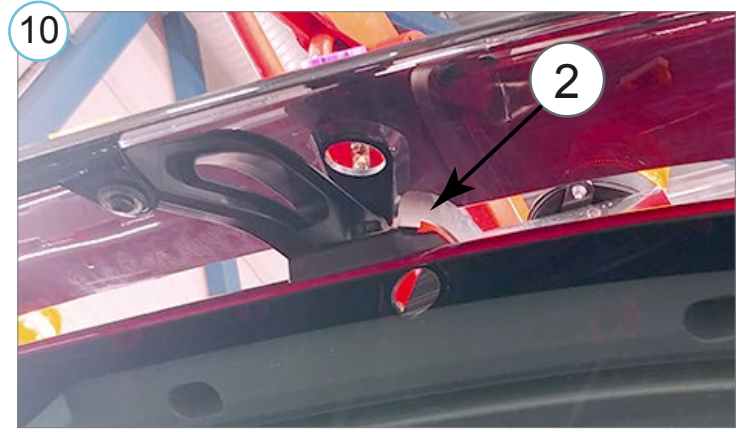
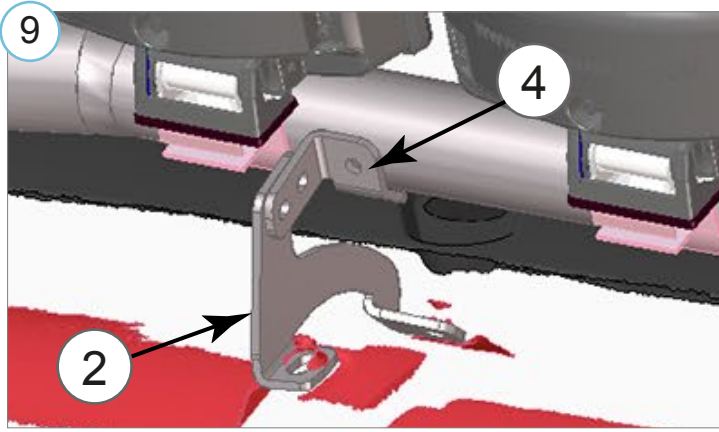

12 Elektrihendused teostada kvalifitseeritud autoelektriku poolt

Installation of the lights can be carried out by qualified electrician only

Монтаж огней может быть выполнено только квалифицированным электриком

Die Installation der Lichter können durchgeführt werden durch Elektrofachkraft

Switching pattern of the lights of the holder.

Juhul kui lampide A+B+C koguvõimsus ületab 280 W tuleb juhtmesarja võimalikke signaali juhtmeid (A/B) kasutada täiendavaks maanduseks! Erinevate laternate võimalik samaaegsete lülituste arv väheneb.

If the total wattage of the headlights A+B+C exceeds 280 W, the signal cables of the wiring harness (A/B) must be used as additional grounding! The number of possible simultaneous switching of different headlamps is decreasing.

Если общая мощность фар A+B+C превышает 280 Вт, сигнальные кабели жгута проводов (A/B) следует использовать в качестве дополнительного заземления! Количество возможных одновременных переключений различных фар уменьшается.

Falls die Gesamtleistung der Scheinwerfer A+B+C 280 W übersteigt, sind die eventuellen Signalkabel des Kabelbaums (A/B) als zusätzliche Erdung zu verwenden! Die Anzahl möglicher gleichzeitiger Schaltungen verschiedener Scheinwerfer verringert sich.

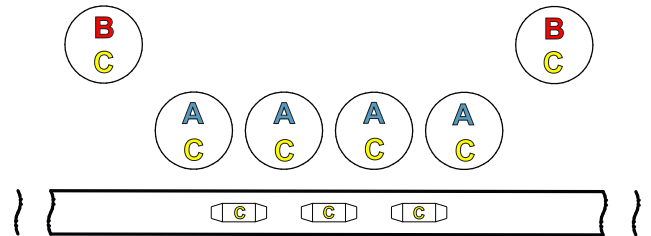

| possible switch ON position | Harness ID number references / Juhtmesarjade viited | | | |
|-----------------------------|---|---------|---------|--------|
| | 5G1,5 | 3G1,0 B | 3G1,0 A | 2G0,75 |
| C+ | 1 | 1 | 1 | 2 |
| A - | Gr/y | Gr/y | | 1 |
| B + | 2 | | 2 | |
| A + | 3 | 2 | | |
| B - | 4 | | Gr/y | |