

BATV590FH BATV591FH

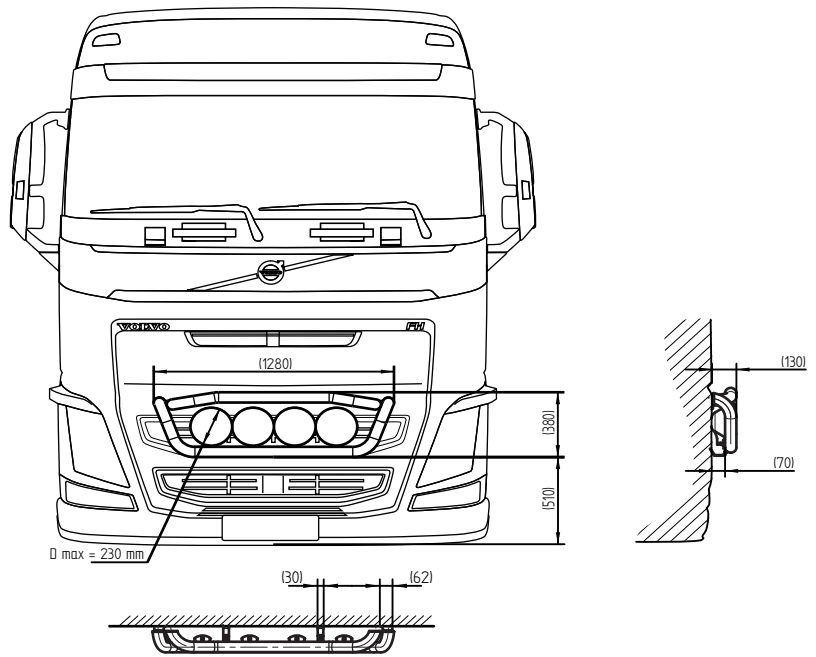

1. lampholder	1	6. spring washer A10	2
2. front pipe	1	7. bolt M10x25 mm	4
3. bracet	2	8. nut M10 DIN 985	2
4. bracet	1	9. washer 10,5x20x2 mm	4
5. bracet	1	10. washer 10,5x30x2,5 mm	2

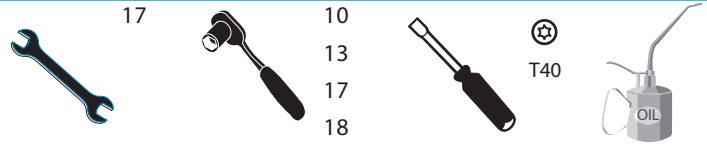

- dimensions : 125x350x1300 mm.
- poids : 10,9 kg.

- Temps de montage : 40 min.

